

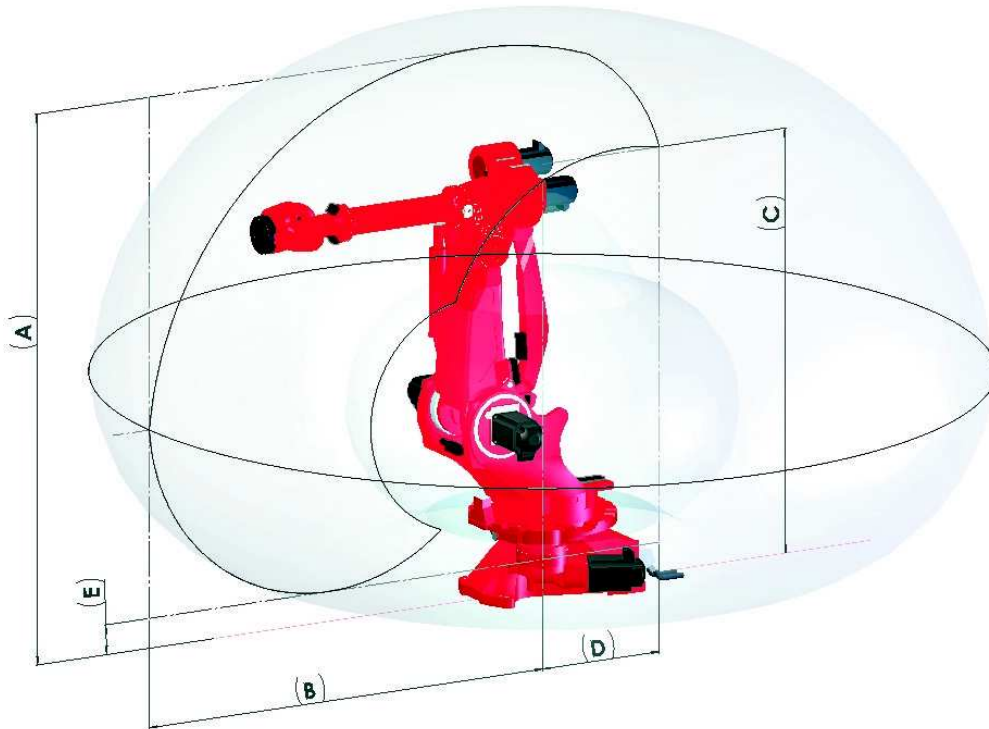

Payload up to
370 Kg ■

Maximum horizontal reach
3.000 mm ■

Repeatability
0,15 mm ■



- Assembly
- Foundry
- Handling Packaging
- Machine Tending
- Measuring Testing
- Polishing Deburring
- Processing Machining
- Spot Welding
- Wood-Glass Machining

ROBOT APPLICATIONS

Model	NJ 370-2.7	NJ 290-3.0		
Number of axes	6	6		
Load at wrist (Kg)	370	290		
Additional load on forearm (Kg)	50	50		
Torque of axes (Nm)	4	2.109	1.668	
	5	2.109	1.668	
	6	1.177	1.177	
Axes stroke (Speed)	1	+/- 180° (90°/s)	+/- 180° (90°/s)	
	2	+/- 75° (90°/s)	+/- 75° (90°/s)	
	3	0°-231° (90°/s)	0°-220° (90°/s)	
	4	+/- 2.700° (105°/s)	+/- 2.700° (105°/s)	
	5	+/- 125° (105°/s)	+/- 125° (105°/s)	
	6	+/- 2.700° (160°/s)	+/- 2.700° (160°/s)	
Repeatability ISO 9283 (mm)	0,15	0,15		
Maximum horizontal reach (mm)	2.700	3.000		
Installation position	Floor	Floor		
Protection Class	IP65/IP67 wrist	IP65/IP67 wrist		
Operating Areas (mm)	A	3.392	3.680	
	B	2.700	3.000	
	C	2.617	2.922	
	D	804	804	
	E	181	119	
Foundry version	Available	Available		

Sales • +39 011 0045406 • sales.robotics@comau.com
 Service • +39 011 0045553 • service.robotics@comau.com
www.comau.com/robotics

